



FUJI ELECTRIC

SPLIT TYPE ROOM AIR CONDITIONER

WALL MOUNTED type

SERVICE MANUAL

Models	Indoor unit	Outdoor unit
	RSW-14A	ROW-14A
	RSW-147	ROW-14AA
	RSW-14RA	ROW-14R
	RSW-147R	ROW-14RA

C O N T E N T S

SPECIFICATIONS	1
REFRIGERANT SYSTEM DIAGRAM	2
CIRCUIT DIAGRAM	3
INDOOR PRINTED CIRCUIT BOARD CIRCUIT DIAGRAM	5
P.C. BOARD LAYOUTS	9
DISASSEMBLY ILLUSTRATION	10
PARTS LIST	14



Большая библиотека технической документации

<https://splitsystema48.ru/instrukcii-po-ekspluatácii-kondicionerov.html>

каталоги, инструкции, сервисные мануалы, схемы.

S P E C I F I C A T I O N S

TYPE		COOLING		COOL & HEAT	
INDOOR UNIT		RSW-14A, RSW-147	RSW-14A, RSW-147	RSW-14RA, RSW-147R	RSW-14RA, RSW-147R
OUTDOOR UNIT		ROW-14A	ROW-14AA	ROW-14R	ROW-14RA
COOLING CAPACITY	(kW)	3.85 - 4.00	3.85 - 4.00	3.85 - 4.00	3.85 - 4.00
HEATING CAPACITY	(kW)	—	—	4.65 - 4.80	4.65 - 4.80

ELECTRICAL DATA

POWER SOURCE		(V)	220 - 240			
FREQUENCY		(Hz)	50			
RUNNING CURRENT	(A)	COOLING	7.6 - 7.8	7.6 - 7.8	7.6 - 7.8	7.6 - 7.8
		HEATING	—	—	7.8 - 8.2	7.8 - 8.2
INPUT WATTS	(kW)	COOLING	1.62 - 1.72	1.62 - 1.72	1.65 - 1.75	1.65 - 1.75
		HEATING	—	—	1.71 - 1.83	1.71 - 1.83
EER	(kW/kW)	COOLING	2.38 - 2.33	2.38 - 2.33	2.33 - 2.29	2.33 - 2.29
		HEATING	—	—	2.72 - 2.62	2.72 - 2.62
MOISTURE REMOVAL		(ℓ/hr)	1.6			
AIR CIRCULATION-Hi		(m ³ /hr)	540			

COMPRESSOR

TYPE		Hermetic type, Permanent split condenser, 2 pole, Single phase, Induction motor				
CODE		2KS282D5AA01	QJ282PC24A	2KS282D5AA01	QJ282PC24A	
REFRIGERANT	R-22	(g)	1,000	1,090	1,050	1,100

FAN MOTOR

POWER SOURCE		(W)	240			
INDOOR UNIT	TYPE		MFA-17AT			
	HI-SPEED	(r.p.m.)	1,240			
	MED-SPEED	(r.p.m.)	1,160			
	LO-SPEED	(r.p.m.)	1,080			
OUTDOOR UNIT	TYPE		MFB-14VTB			
	(r.p.m.)		750			

DIMENSIONS

INDOOR UNIT	H x W x D	(mm)	285 x 900 x 172			
OUTDOOR UNIT			530 x 750 x 250			

WEIGHTS

INDOOR UNIT	GROSS / NET	(kg)	13 / 10			
OUTDOOR UNIT			39 / 37	38 / 36	40 / 38	39 / 37

ADDITIONAL REFRIGERANT CHARGE

PIPE LENGTH		16 ft. (5 m)	23 ft. (7 m)	33 ft. (10 m)
FULL CHARGE AMOUNT	ROW-14A	1,000g (35.3oz.)	1,040g (36.7oz.)	1,100g (38.9oz.)
	ROW-14AA	1,090g (38.4oz.)	1,130g (39.9oz.)	1,190g (42.0oz.)
	ROW-14R	1,050g (37.0oz.)	1,090g (38.4oz.)	1,150g (40.6oz.)
	ROW-14RA	1,100g (38.8oz.)	1,140g (40.2oz.)	1,200g (42.3oz.)

Note : Between 5 m and 10 m, when using a connection pipe other than that in the table, charge additional refrigerant with 20 g (0.71 oz.) / 1 m (3.3 ft.) for ROW-14A, ROW-14AA, ROW-14R and ROW-14RA as the criteria.

REFRIGERANT SYSTEM DIAGRAM

Models : RSW-14A / ROW-14A
RSW-147 / ROW-14AA

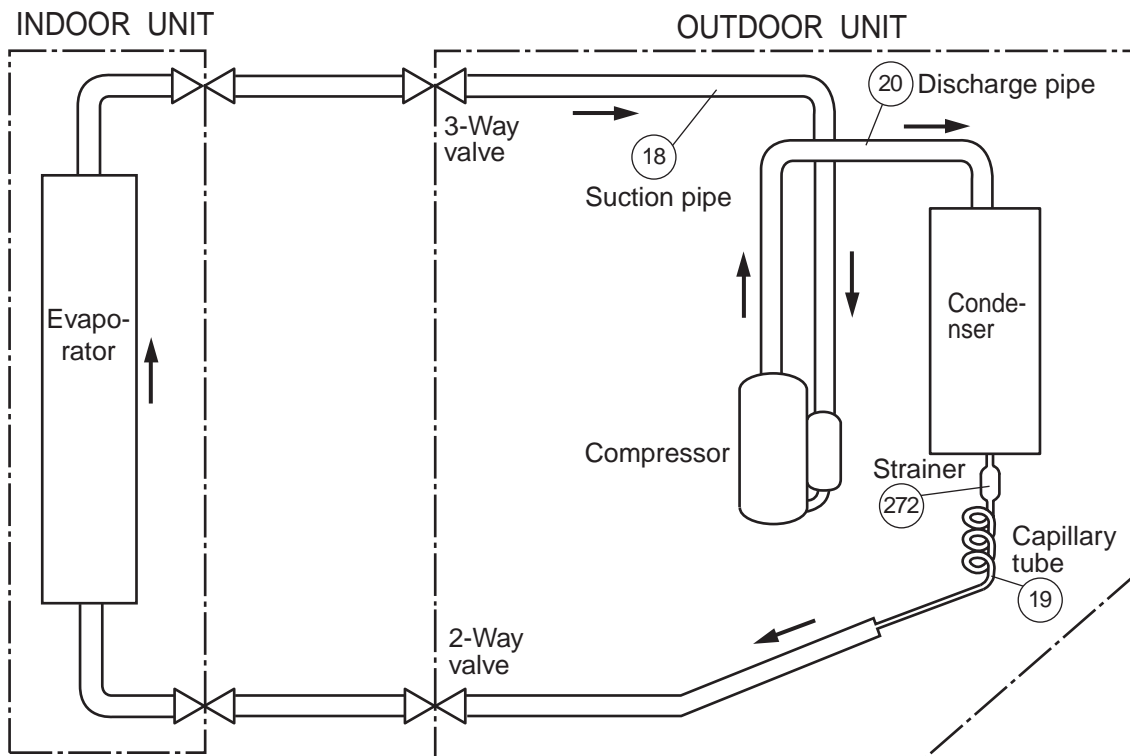

Models : RSW-14RA / ROW-14R
RSW-147R / ROW-14RA

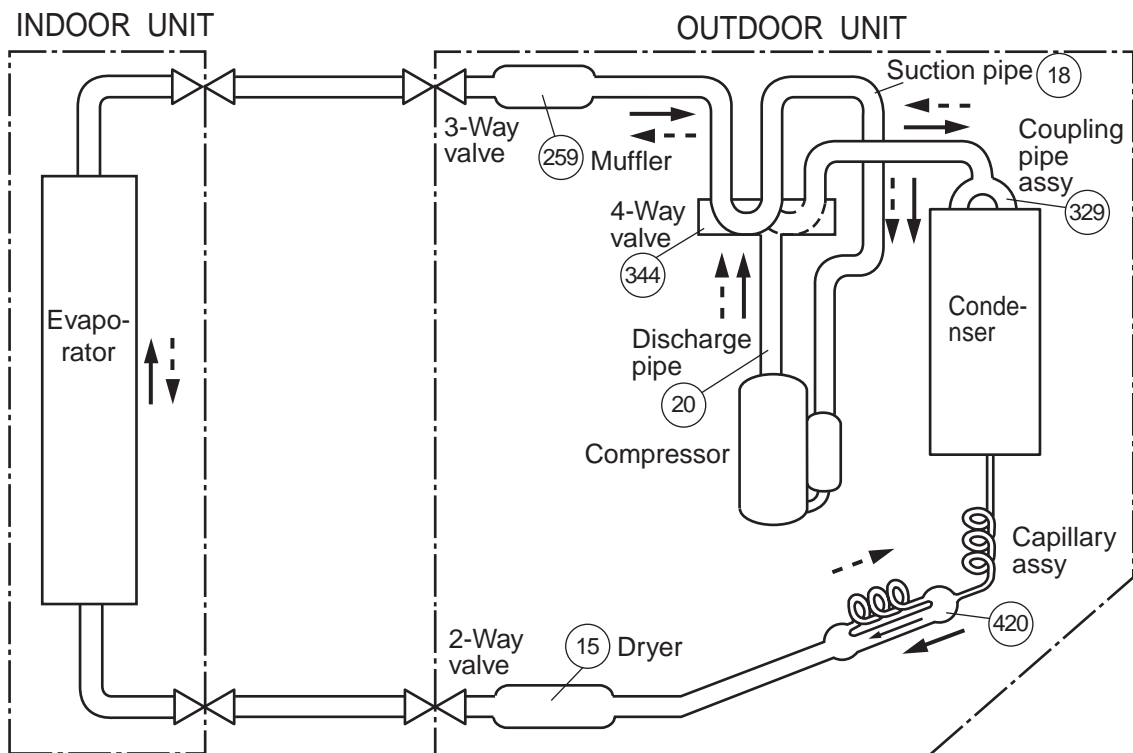

CIRCUIT DIAGRAM

Models : RSW-14A / ROW-14A
RSW-147 / ROW-14AA

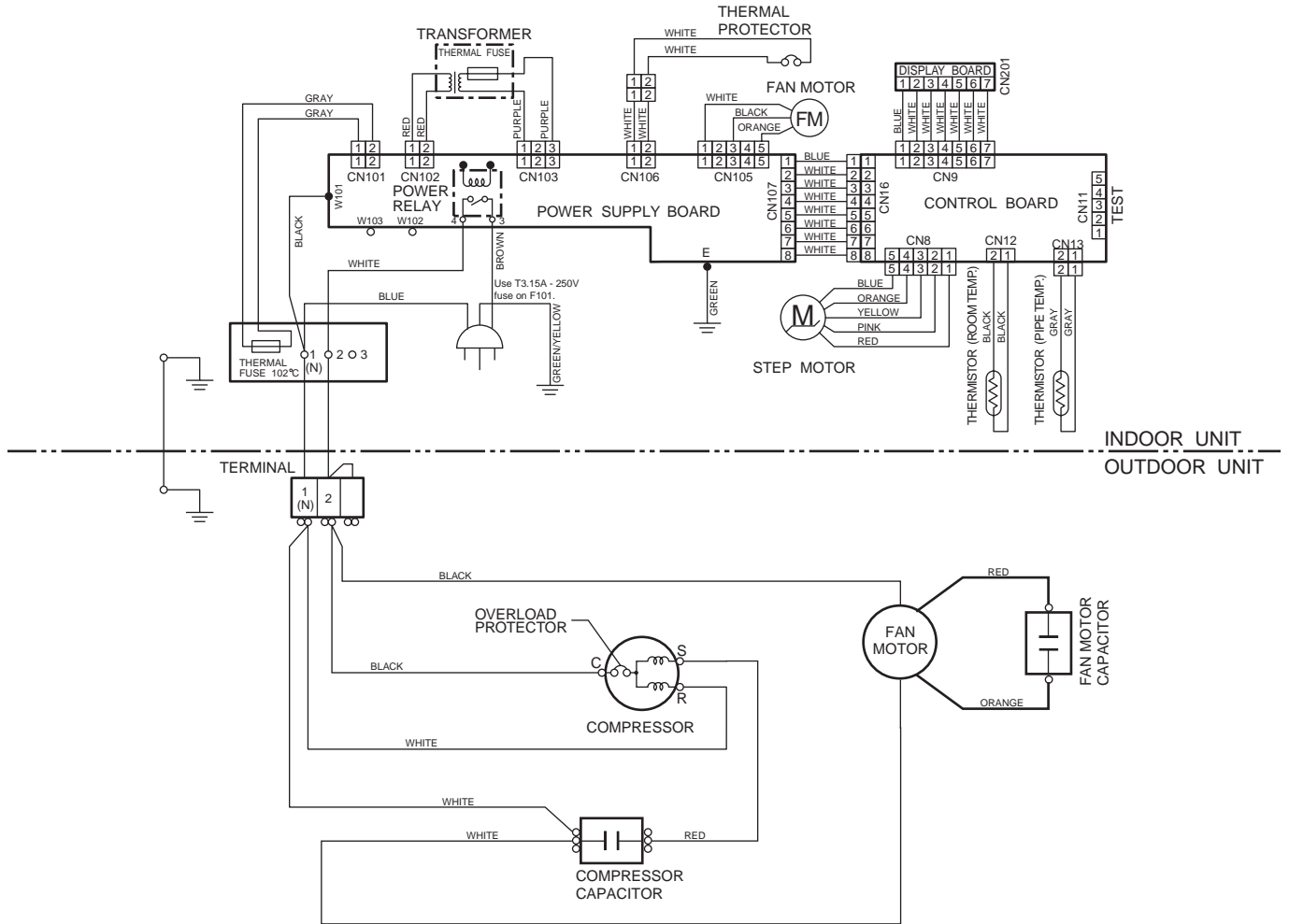

**Models : RSW-14RA / ROW-14R
RSW-147R / ROW-14RA**

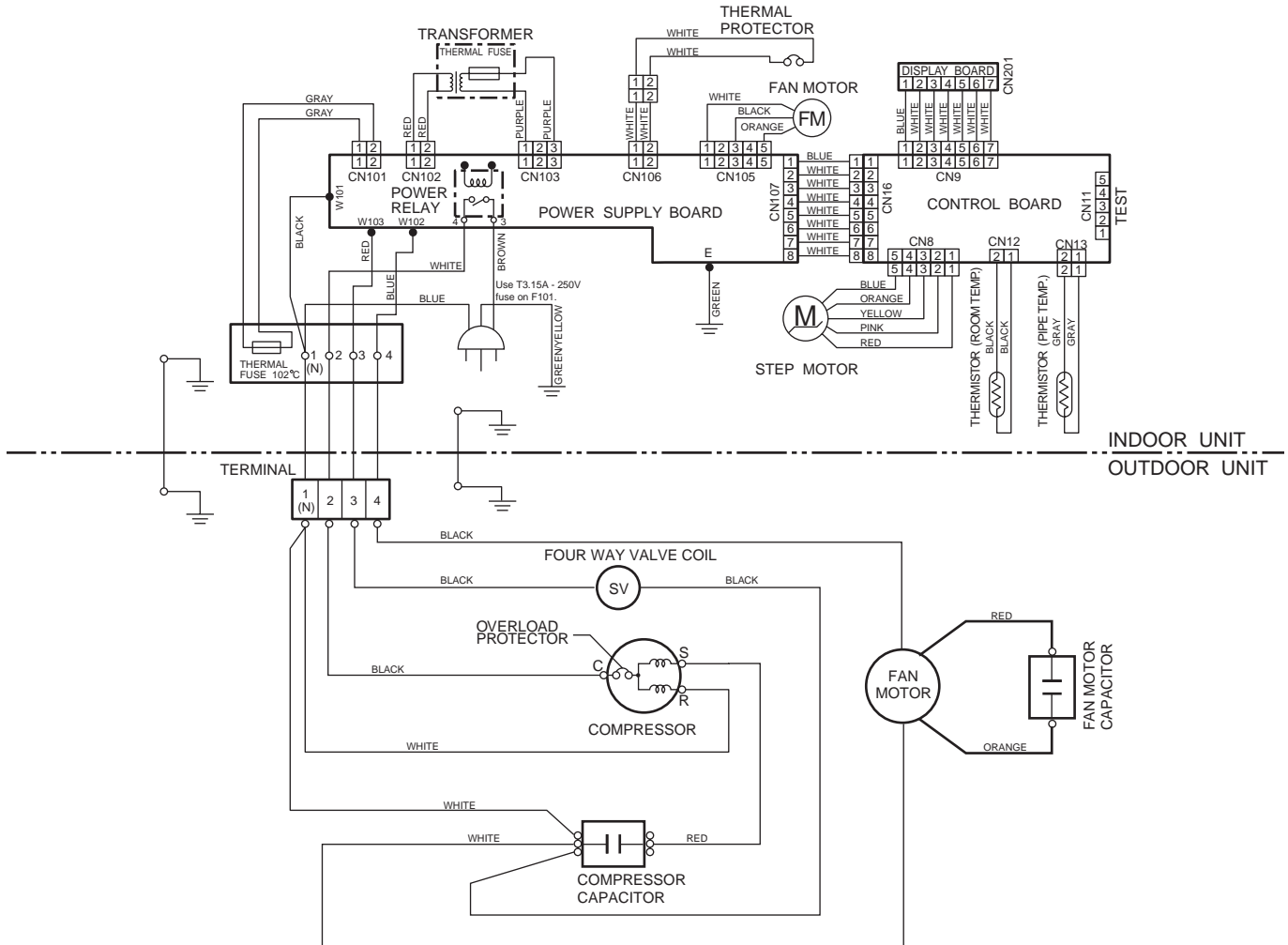

INDOOR PRINTED CIRCUIT BOARD CIRCUIT DIAGRAM

Model : RSW-14A

CONTROLLER PCB ASSEMBLY (MAIN PCB)
EZ-09707WSE-C (GM-60102)

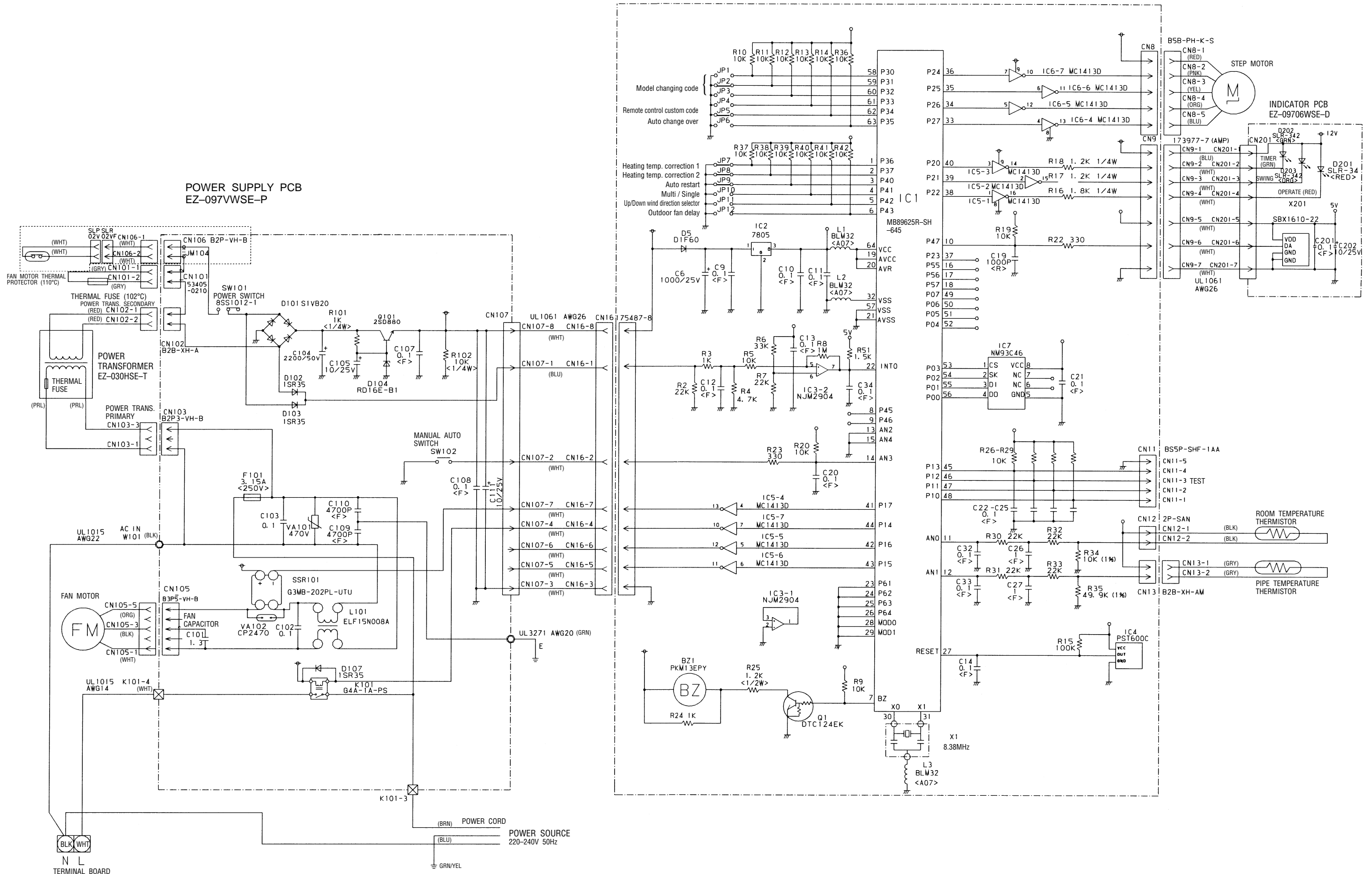

Model : RSW-14RA

CONTROLLER PCB ASSEMBLY (MAIN PCB)

EZ-09705HSE-C (GM-60101)

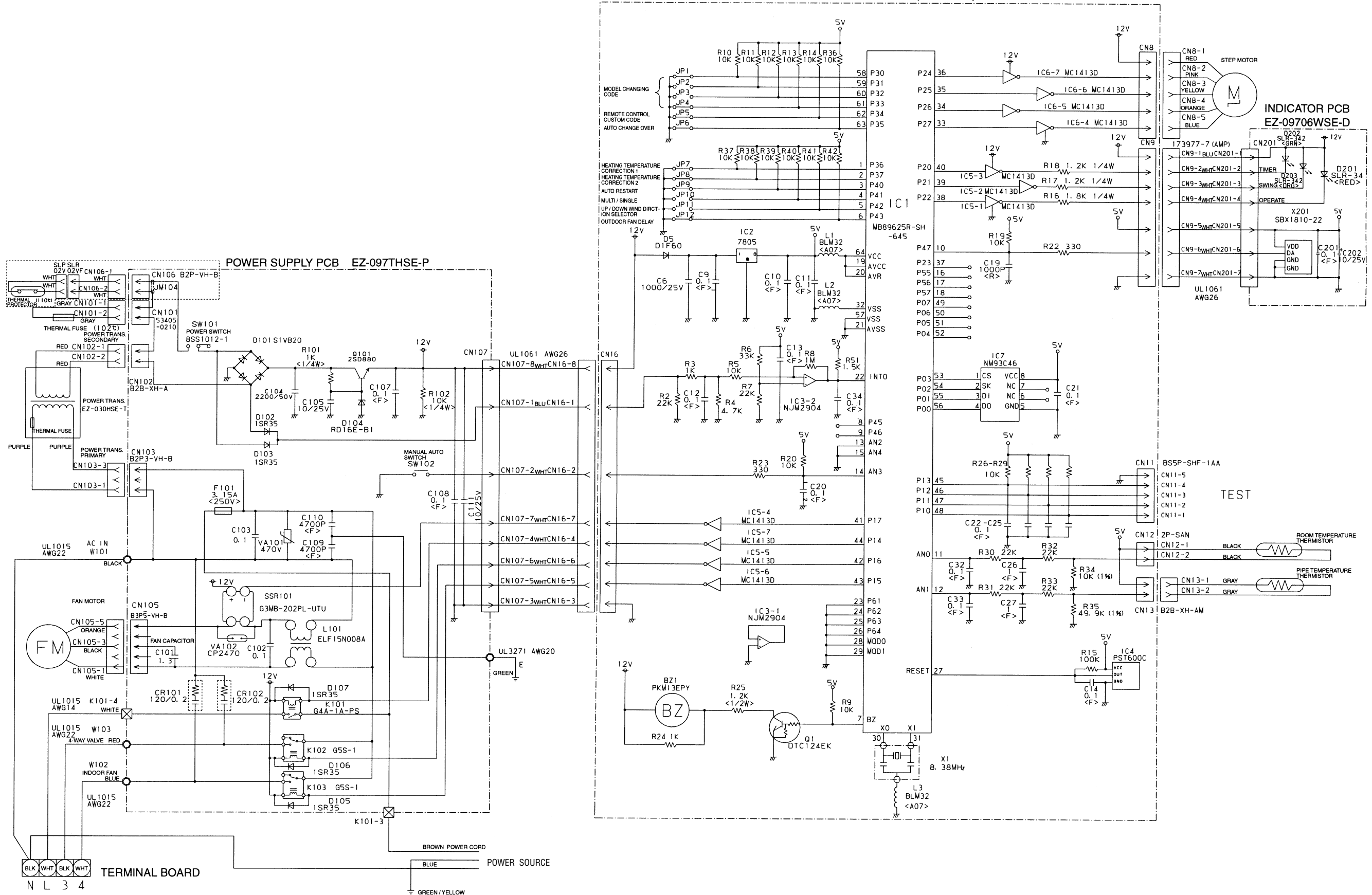

Model : RSW-147

CONTROLLER PCB ASSEMBLY (MAIN PCB) EZ-095GWSE-C (GM-6805)

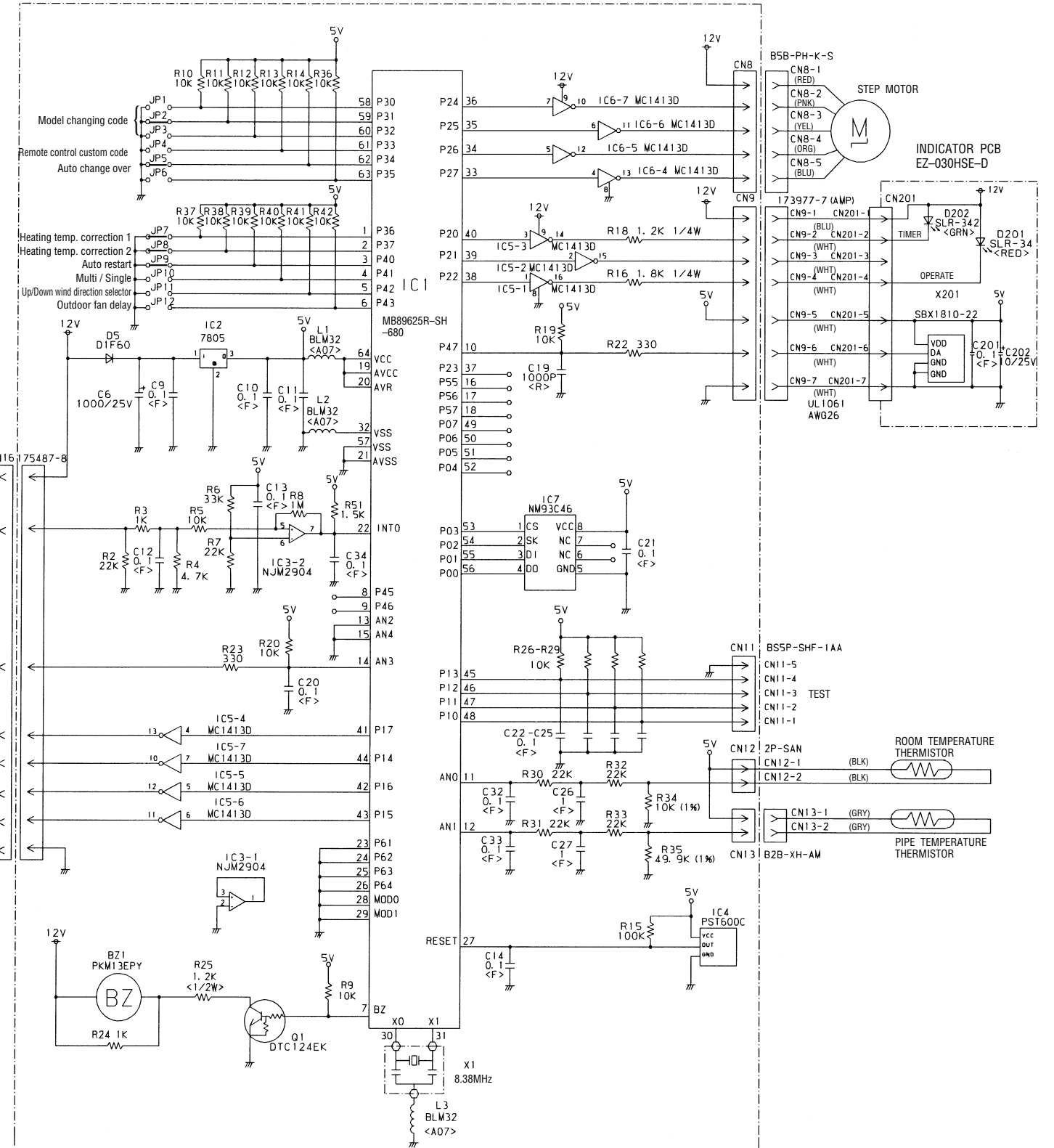
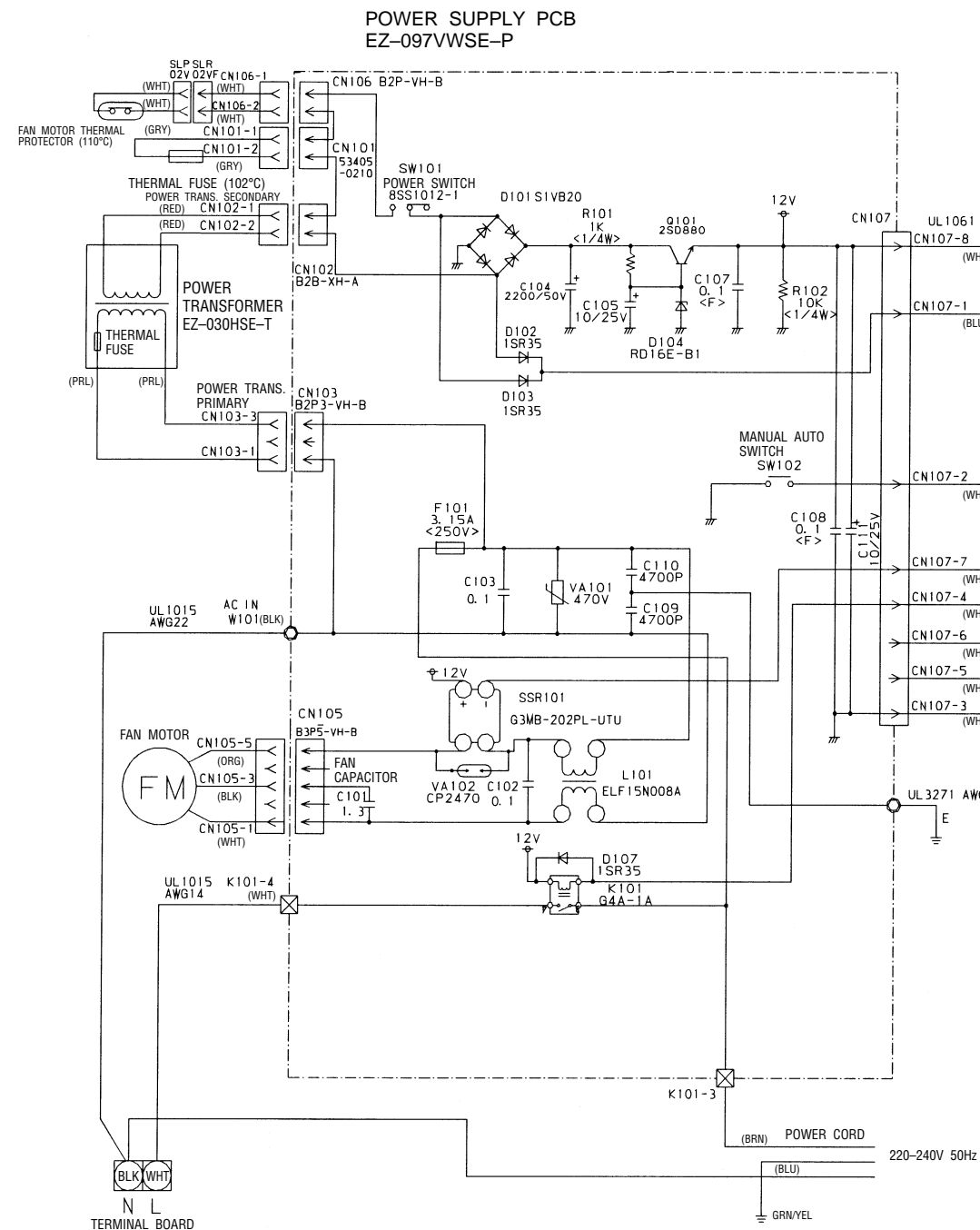

CONTROLLER PCB ASSEMBLY (MAIN PCB)
EZ-0960HSE-C (GM-6844)

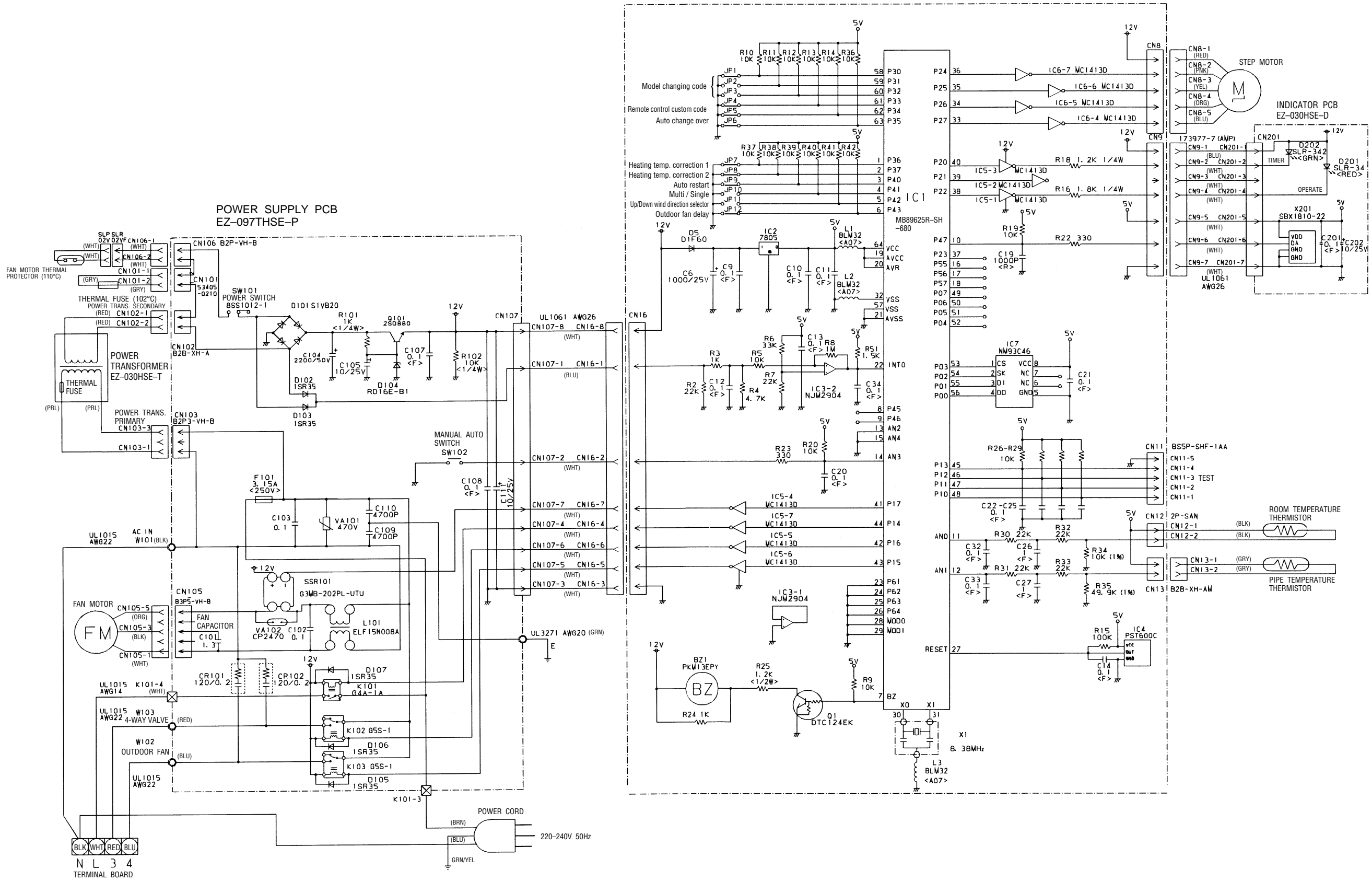

P. C. BOARD LAYOUTS

CONTROLLER P. C. BOARD ASSEMBLY

(Viewed from the solder side)

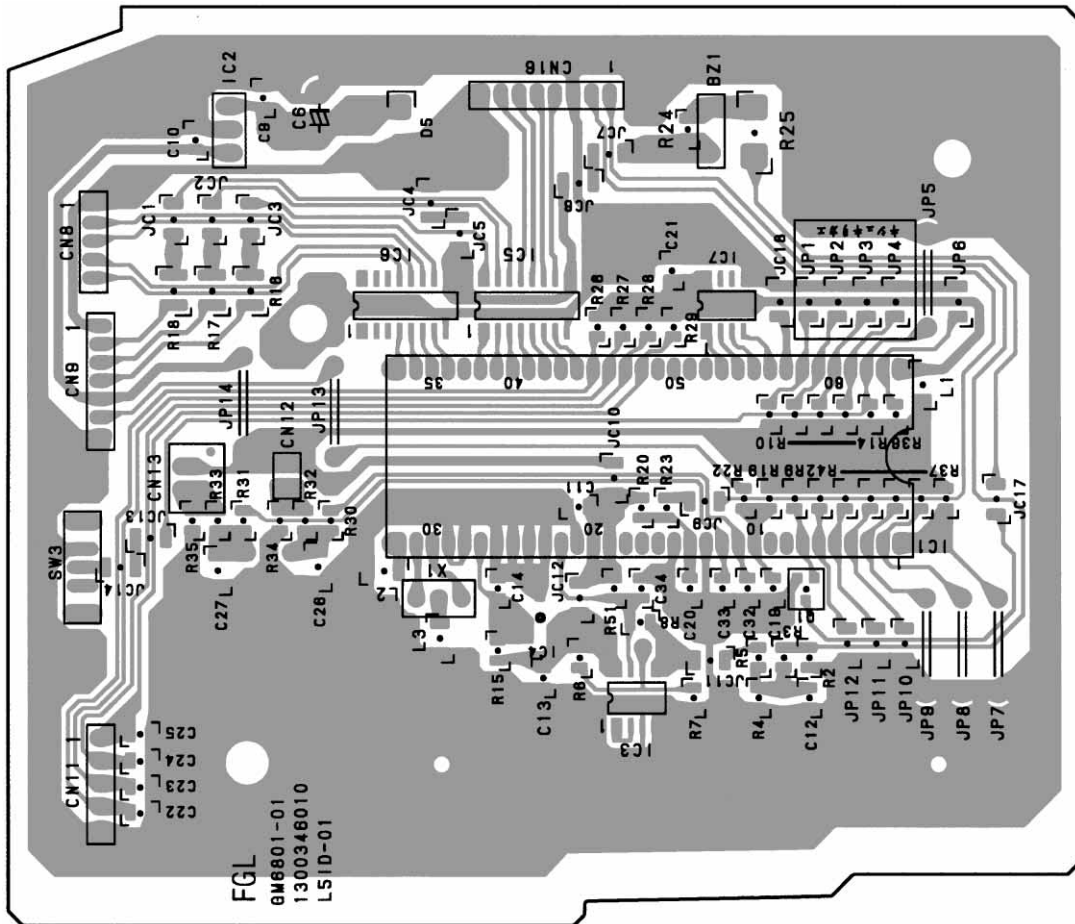

INDICATOR P. C. BOARD ASSEMBLY

(Viewed from the solder side)

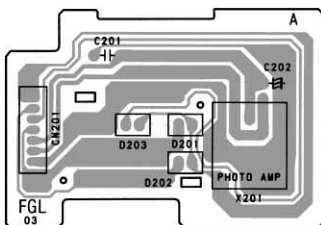

FILTER P. C. BOARD ASSEMBLY

(Viewed from the solder side)

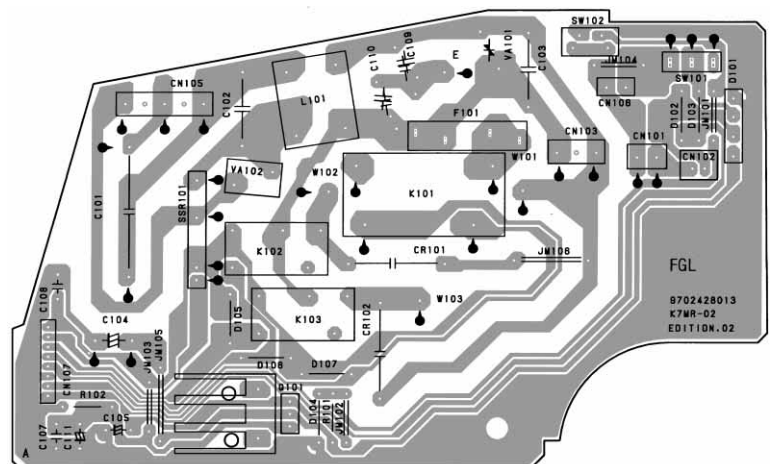

DISASSEMBLY ILLUSTRATION

Models : RSW-14A, RSW-14RA
RSW-147, RSW-147R

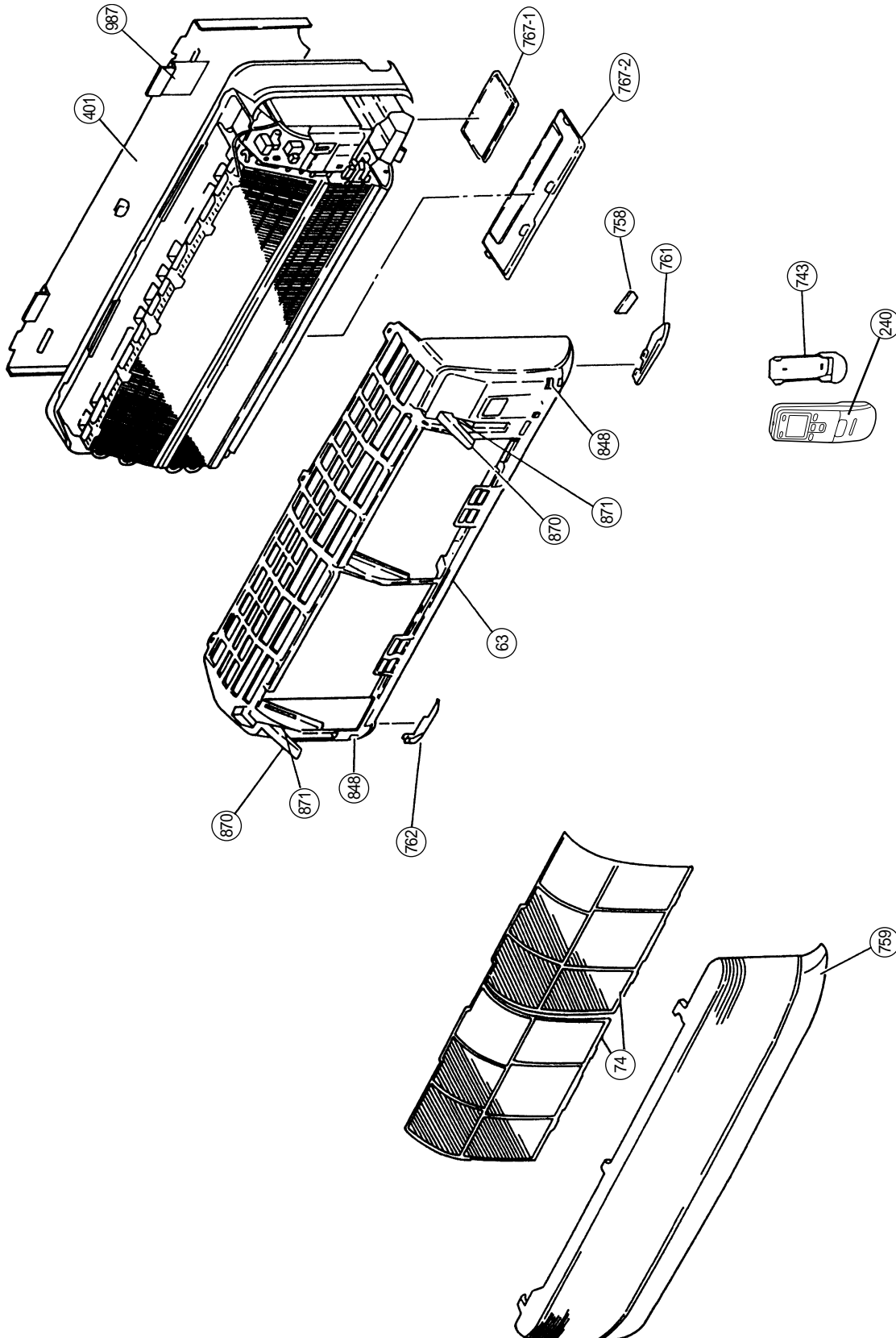

Models : ROW-14A, ROW-14AA
ROW-14R, ROW-14RA

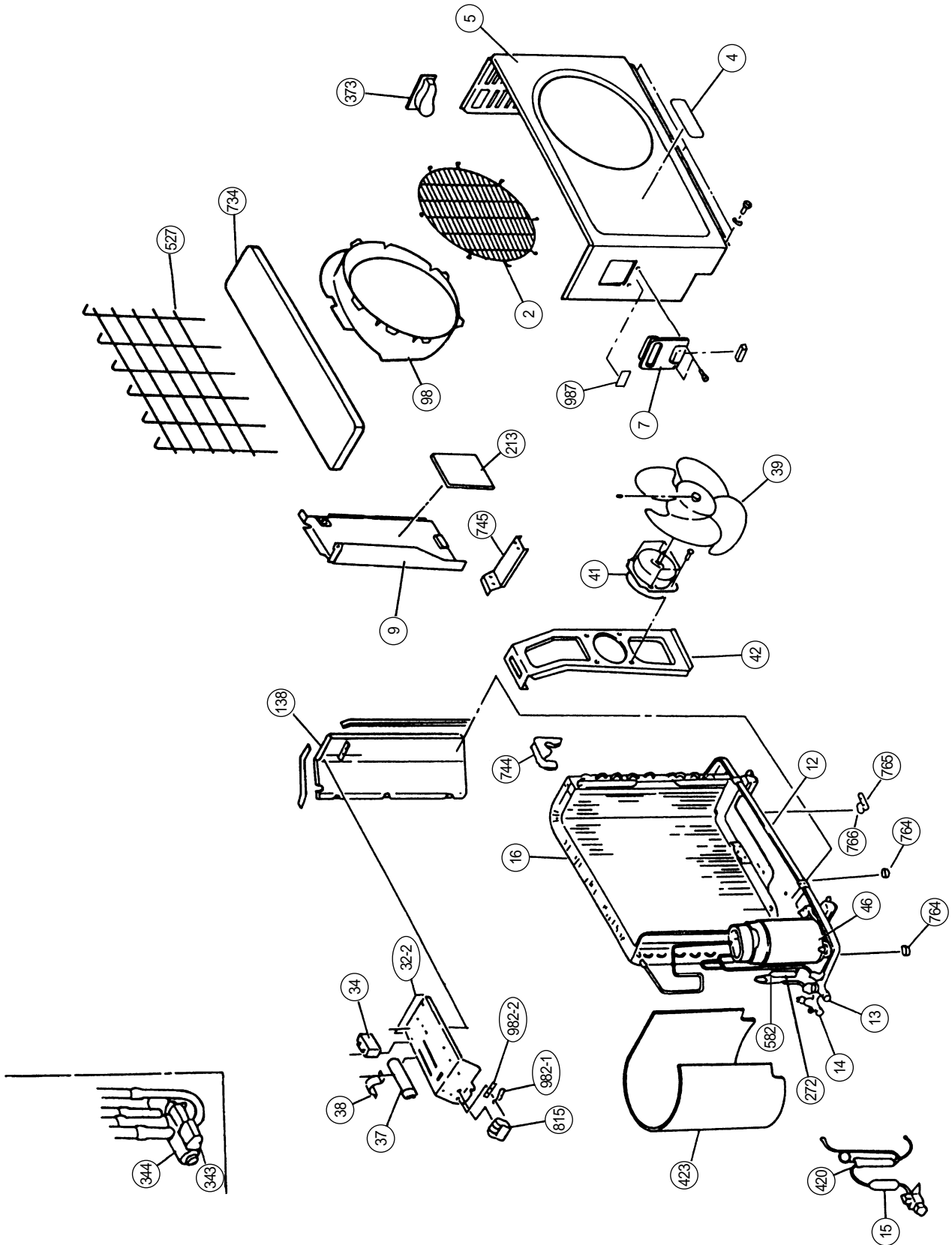

Models : ROW-14A, ROW-14AA
ROW-14R, ROW-14RA

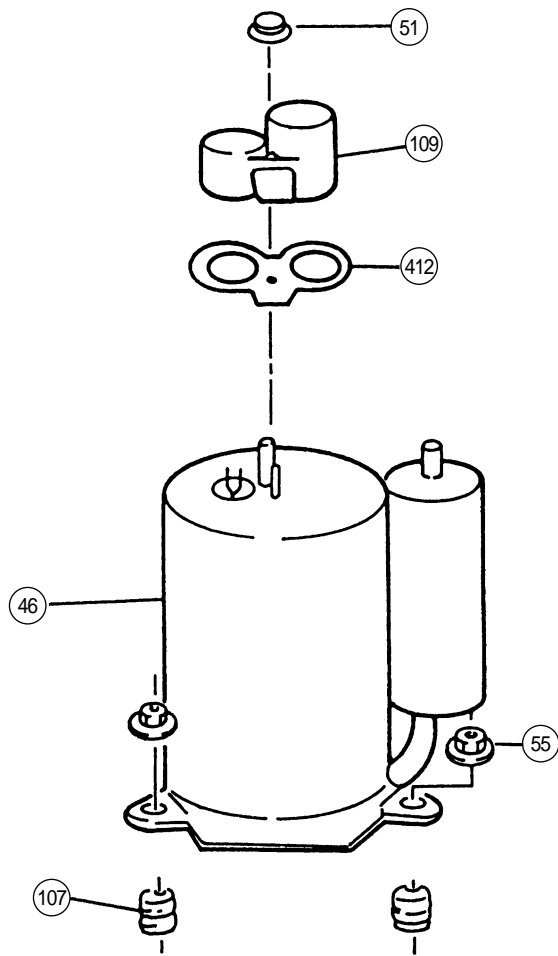

PARTS LIST

When you order parts, please make a photocopy of this page and fill the number of the parts in the "Order" column.

INDOOR UNIT

Ref. No.	Description	Part No.				Ord. Q'ty
		RSW-14A	RSW-147	RSW-14RA	RSW-147R	
28	Blower Cover	9304111016	9304111016	9304111016	9304111016	
63	Front Panel Assy	9354229204	9354229174	9354229204	9354229174	
65	Flow Control Panel	9354646032	9354646094	9354646032	9354646094	
74	Filter	9304097013	9304097013	9304097013	9304097013	
108	Base	9304107033	9304107033	9304107033	9304107033	
109	Casing	9304108016	9304108016	9304108016	9304108016	
122	Shaft Holder-B Assy	9304470007	9304470007	9304470007	9304470007	
127	Drain Hose Assy	9304761013	9304761013	9304761013	9304761013	
146	Evaporator Assy	9304079002	9304079002	9304079002	9304079002	
151	Control Box	9304092001	9304092001	9304092001	9304092001	
158	Joint Pipe Assy	9304286011	9304286011	9304286011	9304286011	
164	Fan Motor Assy-IN	9600432013	9600432013	9600432013	9600432013	
169	Cross-Flow Fan Assy	9306327002	9306327002	9306327002	9306327002	
178	Motor Cushion-G	9304669005	9304669005	9304669005	9304669005	
184	Thermistor Spring-A	313728262708	313728262708	313728262708	313728262708	
185	Wire Clamp	9356959000	9356959000	9356959000	9356959000	
188	Power Cord Assy	9701149049	9701149049	9701149049	9701149049	
233	Power Transformer	9701803026	9701803026	9701803026	9701803026	
235	Thermistor Assy-Pipe	9702325015	9702325015	9702325015	9702325015	
236	Controller PCB Assy	9702529017	9701553051	9702530037	9701553082	
240	Remote Control Unit	9359960119	9356765076	9359960133	9356765069	
251	Hose Clamp (Drain Hose)	9304077008	9304077008	9304077008	9304077008	
268	Motor Cover-B	9304231004	9304231004	9304231004	9304231004	
281	Clamp Metal (Pipe)	9304242000	9304242000	9304242000	9304242000	
283	Bushing-A	9303529010	9303529010	9303529010	9303529010	
345	Filter Guide	9304110019	9304110019	9304110019	9304110019	
385	Indicator PCB Assy	9702511012	9701119011	9702511012	9701119011	
401	Wall Hook Bracket	9304093008	9304093008	9304093008	9304093008	
406	Louver-L Assy	9354644014	9354644014	9354644014	9354644014	
407	Louver-R Assy	9354643017	9354643017	9354643017	9354643017	
425	Earth Terminal	9357852003	9357852003	9357852003	9357852003	
652	Thermistor Holder	313714262805	313714262805	313714262805	313714262805	
736	Operation Panel	9354230002	9354230002	9354230002	9354230002	
743	Remote Control Unit Holder	9305642014	9305642014	9305642014	9305642014	
758	Decoration Plate-A	9360085016	9354223011	9360085016	9354223011	
759	Intake Grille-A "FUJI ELECTRIC"	9355595063	9355595063	9355595063	9355595063	
761	Side Cover-R	9303518076	9303518076	9303518076	9303518076	
762	Side Cover-L	9303520147	9303520147	9303520147	9303520147	
764	Drain Cap	9304150008	9304150008	9304150008	9304150008	
767-1	Bottom Cover-A	9303536056	9303536056	9303536056	9303536056	
767-2	Bottom Cover-B	9303537053	9303537053	9303537053	9303537053	
780	Key Top	9303526002	9303526002	9303526002	9303526002	
815	Terminal-2P	9701955022	9701955022	—	—	
815	Terminal-4P	—	—	9701955039	9701955039	
848	Catcher	9306545000	9306545000	9306545000	9306545000	
870	Arm	9303525005	9303525005	9303525005	9303525005	
871	Arm Spring	9304377009	9304377009	9304377009	9304377009	
872	Indicator Case	9303631003	9303631003	9303631003	9303631003	
874	Control Box Cover	9304094005	9304094005	9304094005	9304094005	
875	Power Supply PCB Assy	9702451028	9702451028	9702451011	9702451011	
876	Step Motor	9304535003	9304535003	9304535003	9304535003	
936	Fan Guard	9356881011	9356881011	9356881011	9356881011	
977	Louver Clip	9356880014	9356880014	9356880014	9356880014	
978	Wire Bracket-L	9356878011	9356878011	9356878011	9356878011	
979	Wire Bracket-R	9356877014	9356877014	9356877014	9356877014	
983	Thermistor Cover	9356882001	9356882001	9356882001	9356882001	
987	Insulation Sheet	9358340004	9358340004	9358340004	9358340004	

When you order parts, please make a photocopy of this page and fill the number of the parts in the "Order" column.

OUTDOOR UNIT

Ref. No.	Description	Part No.				Ord. Q'ty
		ROW-14A	ROW-14AA	ROW-14R	ROW-14RA	
2	Fan Cover	9304109006	9304109006	9304109006	9304109006	
4	Emblem-Rear "FUJI ELECTRIC"	9361328006	9361328006	9361328006	9361328006	
5	Cabinet, Painted	9302936017	9302936017	9302936017	9302936017	
7	Connector Cover (Cabinet)	9357970004	9357970004	9357970004	9357970004	
9	Cabinet Rear Panel	9303744017	9303744017	9303744017	9303744017	
12	Base Assy, Painted	9354493070	9354493070	9354493070	9354493070	
13	3-Way Valve	9364616001	9364616001	9364616001	9364616001	
14	2-Way Valve	9354615004	9354615004	9354615004	9354615004	
15	Dryer	—	—	313523082505	313523082505	
16	Condenser Assy	9365671009	9365671009	9365670002	9365670002	
18	Suction Pipe	9354625006	9364832005	9354055001	9364827001	
19	Capillary Tube	9364666009	9364835006	—	—	
20	Discharge Pipe Assy	9354624009	9364830001	9354056008	9364826004	
32-2	Control Box Metal-A	9355843003	9355843003	9355843003	9355843003	
34	Capacitor (Fan Motor)	9700468080	9700468080	9700468080	9700468080	
37	Capacitor (Running)	9356386073	9356386066	9356386073	9356386066	
38	Clamp Metal (Capacitor)	313468061808	313468061808	313468061808	313468061808	
39	Propeller Fan Assy	9351589011	9351589011	9351589011	9351589011	
41	Motor Induction-Outer	9600649060	9600649060	9600649060	9600649060	
42	Motor Fixing Table	313166243804	313166243804	313166243804	313166243804	
46	Compressor Assy	9357145006	9364723006	9357145006	9364723006	
51	Special Nut M5 (For Comp.)	9300301015	9359430018	9300301015	9359430018	
55	Special Nut M8 (For Comp.)	9355091008	9355091008	9355091008	9355091008	
98	Fan Ring	313166296109	313166296109	313166296109	313166296109	
107	Rubber Seat (For Comp.) -A	9351049010	9359425014	9351049010	9359425014	
109	Terminal Cover (Comp.)	9351048013	9364724003	9351048013	9364724003	
138	Separate Wall	9303729014	9303729014	9303729014	9303729014	
213	Noise Insulation-B	313584258005	313584258005	313584258005	313584258005	
259	Muffler	—	—	313505083900	313505083900	
272	Strainer	9357309002	9357309002	9301340006	9301340006	
329	Coupling Pipe Assy	—	—	9352375002	9352375002	
343	Solenoid Coil	—	—	9359616047	9359616047	
344	4-Way Valve	—	—	313943302804	313943302804	
373	Grip	313166178700	313166178700	313166178700	313166178700	
412	Terminal Gasket (Comp.)	9351051013	9364725000	9351051013	9364725000	
420	Capillary Assy	—	—	9354058002	9364828008	
423	Noise Insulation-F	9350944019	9350944019	9350944019	9350944019	
527	Protection Net	9355444002	9355444002	9355444002	9355444002	
582	Discharge Pipe-F	9301425017	9301425017	—	—	
734	Cabinet Top Plate	9302937014	9302937014	9302937014	9302937014	
744	Clamp (Condenser)	313166374106	313166374106	313166374106	313166374106	
745	Motor Support	313166036308	313166036308	313166036308	313166036308	
764	Drain Cap	—	—	313166024302	313166024302	
765	Drain Pipe L-type	—	—	9301102000	9301102000	
766	Drain Pipe Packing	—	—	9301143003	9301143003	
815	Terminal-3P	9355901024	9355901024	—	—	
815	Terminal-4P	—	—	9358660041	9358660041	
982-1	Cord Clamp	9356857009	9356857009	9356857009	9356857009	
982-2	Cord Clamp-B	9356858006	9356858006	9356858006	9356858006	
987	Insulation Sheet	—	9358372005	—	9358372005	

When you order parts, please make a photocopy of this page and fill the number of the parts in the "Order" column.

CONTROLLER PCB ASSEMBLY (Ref. No. 236)

Ref. No.	Description	Part No.	Ord. Q'ty	Ref. No.	Description	Part No.	Ord. Q'ty
IC1	IC MB89625R-SH-645	1301534010		R34	Res. 10kΩ±0.5%	0200344010	
IC1	IC MB89625R-SH-680	1300413033		R35	Res. 49.9kΩ±0.5%	0200344683	
IC2	IC NJM7805FA	0100462081		R51	Res. 1.5kΩ±5%	0200212784	
IC3	IC NJM2904M	0100534054		JC1~7,9~12, 17,18	Res. 0Ω	0200230016	
IC4	IC PST600CMT	0101461120		JP(1), 2, (4)	Res. 0Ω	0200230016	
IC5,6	IC MC1413D	0101736013		C6	Cap. Elec. 25V 1000μF	0300631256	
IC7	IC NM93C46M8-X	0101622026		C9~14,20~25, 32~34	Cap. Ceramic 0.1μF	1902783046	
Q1	Xstr DTC124EKA	0000936033		C19	Cap. Ceramic 1000pF	1902829072	
D5	Diode D1F60	0000208024		C26,27	Cap. Ceramic 1μF	1800119015	
R2,7,30~33	Res. 22kΩ±5%	0200213095		X1	Ceramic Resonator CST8.38MTW-TF01	1300116019	
R3,24	Res. 1kΩ±5%	0200212746		BZ1	Buzzer PKM13EPY-4000-TF01	9701298013	
R4	Res. 4.7kΩ±5%	0200212906		L1~3	EMI Filter BLM 31 A601S	0400119029	
R5,9~14,19,20, 26~29,36~42	Res. 10kΩ±5%	0200213019		CN8	Plug, PCB B5B-PH-K-S	0500200061	
R6	Res. 33kΩ±5%	0200213132		CN9	Plug, PCB 175487-7	0500891016	
R8	Res. 1MΩ±5%	0200213491		CN11	Plug, PCB BS5P-SHF-1AA	0500898015	
R15	Res. 100kΩ±5%	0200213255		CN12	Plug, PCB 150-103-86100	9700801023	
R16	Res. 1.8kΩ±5%	0200691725		CN13	Plug, PCB B2B-XH-A	0500005055	
R17,18	Res. 1.2kΩ±5%	0200691534		CN16	Plug, PCB 175487-8	0500891023	
R22,23	Res. 330Ω±5%	0200212623					
R25	Res. 1.2kΩ±5%	0201001769					

POWER SUPPLY PCB ASSEMBLY (Ref. No. 875)











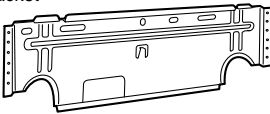

() : Reverse cycle model

Ref. No.	Description	Part No.	Ord. Q'ty	Ref. No.	Description	Part No.	Ord. Q'ty
Q101	Xstr 2SD880	0000001014		SW102	Push KSM0632B	9703476013	
D101	Diode S1VB20	0000292054		F101	Fuse BET 3.15A-250V	0600222512	
D102,103, (105,106),107	Diode 1SR35-200A	0000016018		CN101	Plug, PCB 53405-0210	0500940011	
D104	Diode RD16EB1	0000296014		CN102	Plug, PCB B2B-XH-A	0500005055	
R101	Res. Carbon 1/4W 1kΩ±5%	0201038758		CN103	Plug, PCB B2P3-VH-B	0500011728	
R102	Res. Carbon 1/4W 10kΩ±5%	0201005019		CN105	Plug, PCB B3P5-VH-B	0500011735	
C101	Cap. Plastic 400V 1.3μF	0300939048		CN106	Plug, PCB B2P-VH-B	0500011124	
C102,103	Cap. Plastic 0.1μF	0300304075		CN107	Wire w/Connector L=180mm	9701052011	
C104	Cap. Elec. 50V 2000μF	0301190981		JM101~103	Wire 0.6mm dia. L=10mm	9700025016	
C105,111	Cap. Elec. 25V 10μF	0300007341		JM105, (106)	Wire 0.6mm dia. L=15mm	9700672012	
C107,108	Cap. Ceramic 0.1μF	0300988251		HT	Heat sink PUG-16	9701189014	
C109,110	Cap. Ceramic 4700pF	0300209110		W101	Wire w/Terminal L=190mm BLK	9701169191	
VA101	Varistor ERZ-V10V471CS	0000515139		E	Wire w/Terminal L=250mm GRN	9701150014	
VA102	Varistor CP2470-F	9701835010		(CR101,102)	Fuse Holder SN-5057	9700116011	
SSR101	Relay G3MB-202PL-UTU	9701375011		(K102,103)	CR Absorber RPEL-121204-C	9701125012	
K101	Relay G4A-1A-PS	9701024018		(W102)	Relay G5S-1	9701925018	
L101	EMI Filter ELF15N008A	0400165071		(W103)	Wire w/Terminal L=220mm BLU	9701169016	
SW101	Side 8SS1012-1	9701426010			Wire w/Terminal L=220mm RED	9701170012	

INDICATOR PCB ASSEMBLY (Ref. No.385)

Ref. No.	Description	Part No.	Ord. Q'ty
X201	Remote Control Amplifier SBX 1810-22	0101525129	
D201	Diode SLR-34LR RED	0000727013	
D202	Diode SLR-342MG GRN	0000727167	
(D203)	Diode SLR-342DU ORG	0000727150	
	Lamp Cover-A	9303702000	
CN201	Wire w/Connector L=250mm	9700923015	
C201	Cap. Ceramic 0.1μF	0300988251	
C202	Cap. Elec. 25V 10μF	0300328026	

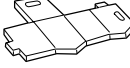
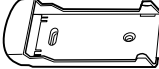
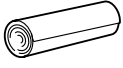
STANDARD ACCESSORIES

Name and Shape	Part No.
Wall hook bracket 	9304093008
Wall cap 	313714296205
Remote control unit 	RSW-14A 9359960119 (AR-DJ15)
	RSW-147 9356765076 (AR-AB25)
	RSW-14RA 9359960133 (AR-DJ17)
	RSW-147R 9356765069 (AR-AB24)
Battery (penlight) 	0600185534
Cable mark (RSW-14RA RSW-147R model only) 	9301385007
Tapping screw (Big) (ø4 x 20) 	0700026034
Tapping screw (Small) (ø3 x 12) 	0700019036
Flange screw (ø4 x 10) 	9305114009
Hexagon wrench 	301980005800
Drain pipe (Including drain packing) (RSW-147R RSW-14RA model only) 	9303029015
Drain Cap (RSW-147R RSW-14RA model only) 	313166024302
Spacer 	
Remote control unit holder 	9305642014
Cloth tape 	9304232001
Seal-A 	9304536000



MANUFACTURER :

Fuji Denki Sosetsu Co., Ltd.

Tokyo, Japan



Большая библиотека технической документации

<https://splitsystema48.ru/instrukcii-po-ekspluatácii-kondicionerov.html>

каталоги, инструкции, сервисные мануалы, схемы.